

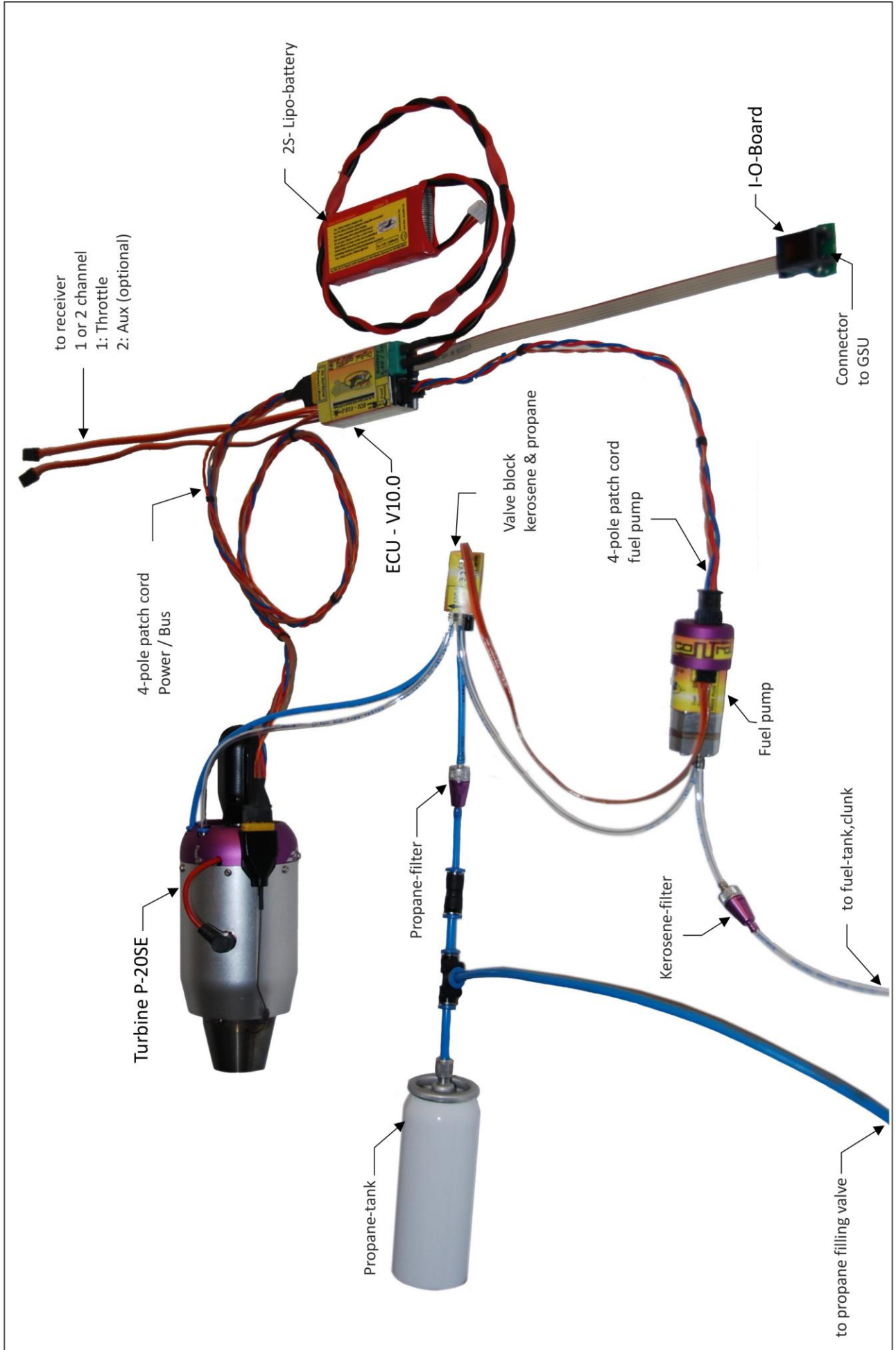

P-20SE connection scheme of all components





Connections of the ECU

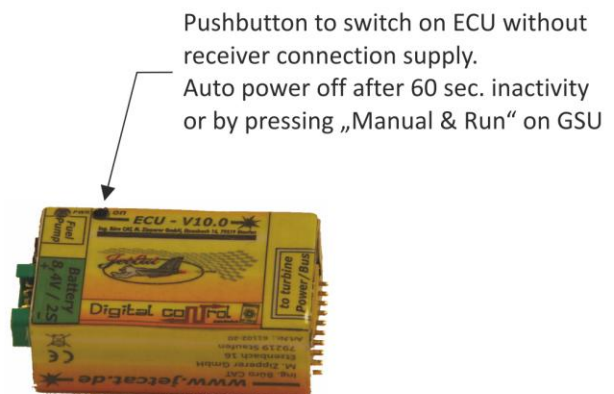
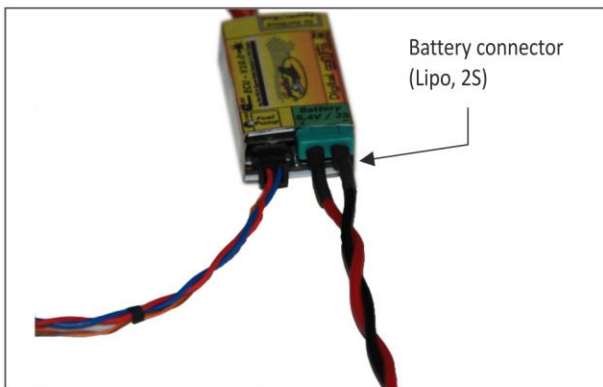
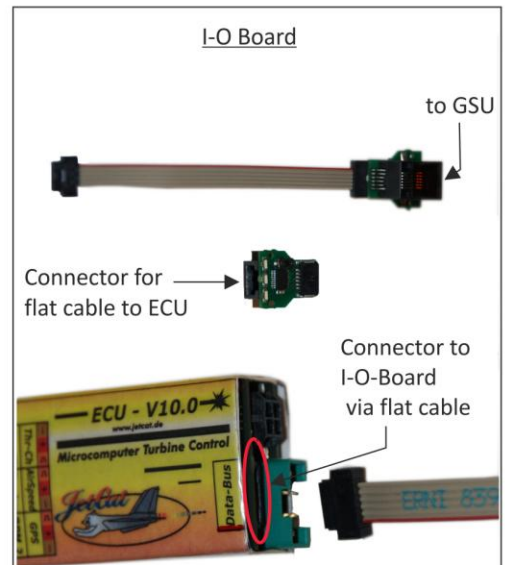
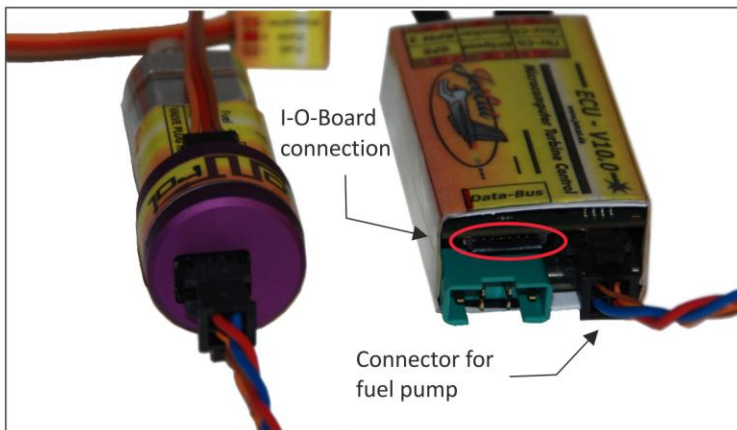
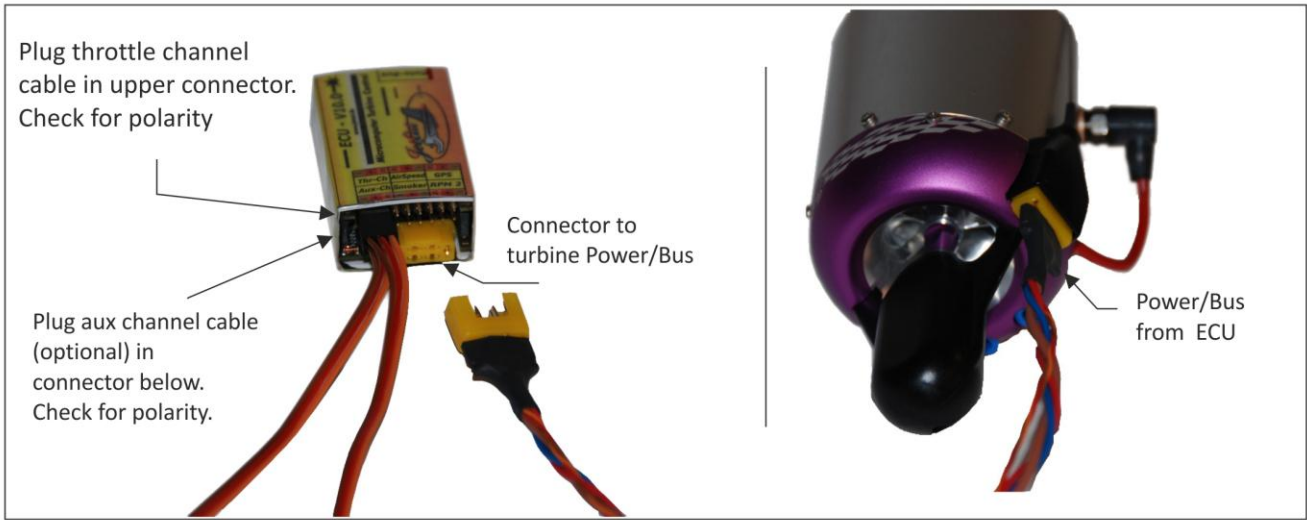



Connection pump and valve block

Valve block connector

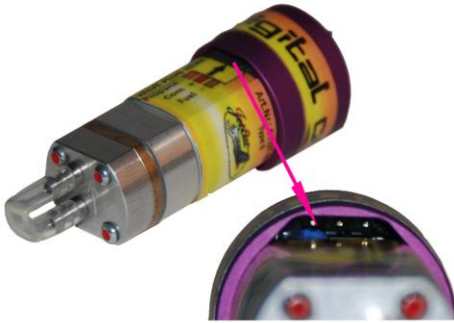

The connector for the valve block is double on both sides under the pump cover.
Plug the valve block cable to any connector.

Pump and valve block connected



Plug the cable according the markings

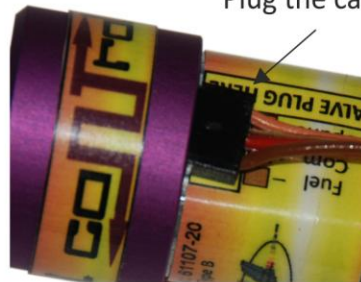

Filter for fuel and propane



For proper handling of the valves the filter must be mounted in front of the valve block. We advise to mount the fuel-filter in front of the pump. The arrow shows the flow direction. Before assembling the filter, put grease on the o-ring and the threads.



P20-SE fuel / propane connection diagram

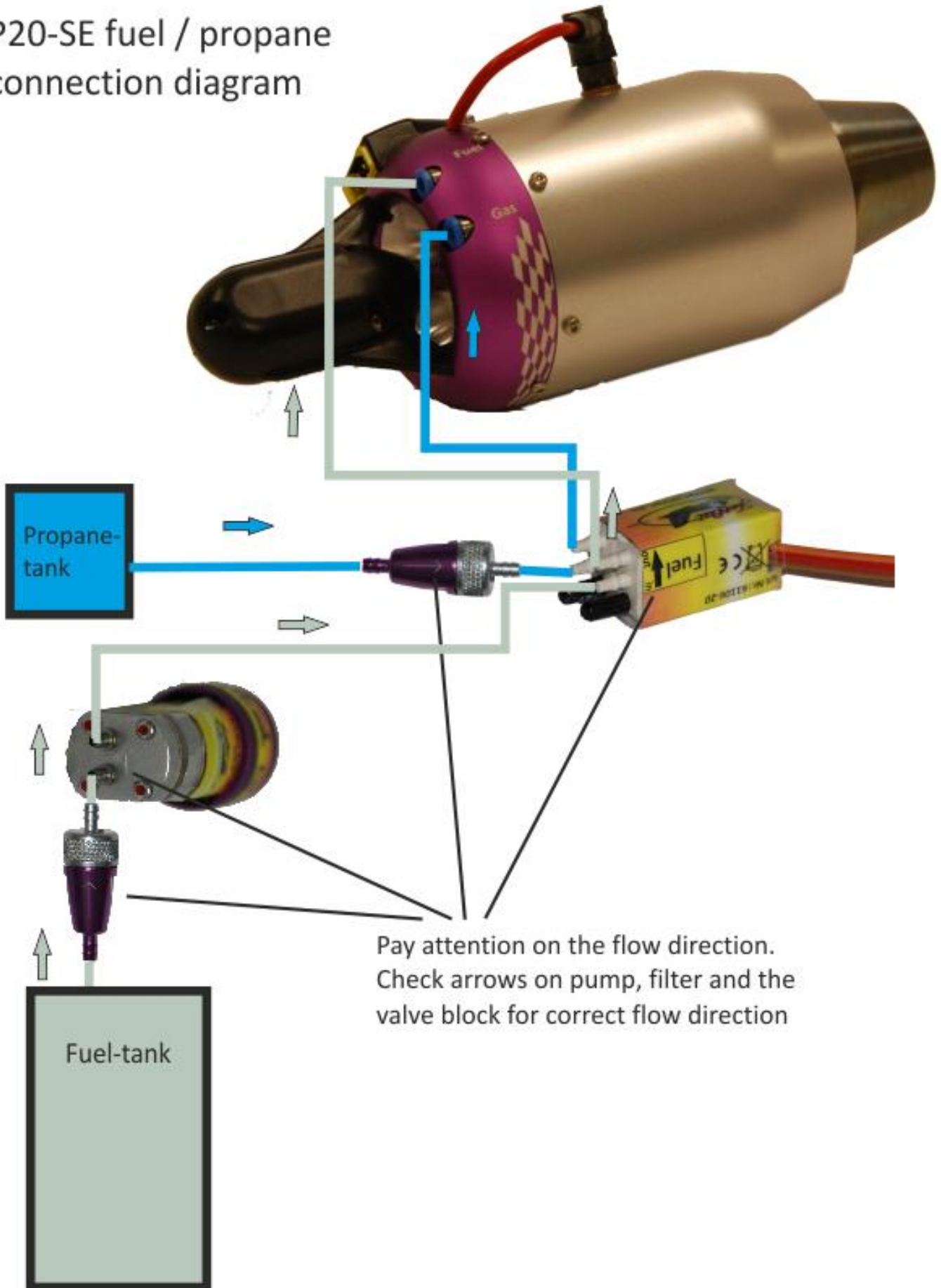



Features of the P20-SE / addition to the instruction manual:

- Switch on of ECU without receiver connection: Press the pushbutton on the ECU for about 5 sec. by using a ball-pen or something similar. ECU will auto power off after 60 sec. inactivity or by pressing “Manual & Run” keys simultaneously on GSU.
- If the ECU was powered up with the transmitter off (=no Servosignal), the ECU power down is also delayed by 60 sec. Use “Ignition & Run” keys to turn off ECU instantly.
- It is not necessary to keep the receiver switched on until the end of the cooling cycle. The ECU is monitoring the cooling sequence and switches off itself automatic after finishing cooling.
- There is no more intermittent action of the starter motor during the cooling sequence anymore. The starter motor runs at a constant speed during cooling.
- There is no need to adjust the pump start voltage anymore.
- Automatic detection and display of the connected pump by the ECU.
- There are three new off conditions added:
 - “Wrong Pmp” -wrong pump type.
Pump type “B” (Art.Nr. 61107-20) is required for P20-SE operation.
 - “No Pump!” – no pump connected or broken.
Pump cable not connected.
 - “Over Curr” – to high current into the engine.
Current to high. Starter jammed.
Glow-plug broken or shorted.



Important

- The fuel and propane filters must be placed between the valve block and fuel pump. Because of the small inner diameters little particles can damage valve and turbine.
- To absorb small pressure pulses generated by the action of the gear pump, the length of the fuel tube on the pressure side must be longer than 110 cm!
- Never remove the closing plugs from the valve block.
- Purge fuel system before first use. Switch to the menu “Test Function” and then to “Purge FuelSystem”. Remove the fuel tube from the turbine and press “Change Value” button. After purging the system reconnect the tube to the engine.
- If the engine stops accelerating when switching from propane to kerosene probably the pump is clogging. After a long time not being used, the fuel pump might stick. To resolve this remove the fuel tube from the engine and go to Test Functions menu / “Purge FuelSystem “ and let the pump run for 2 or 3 minutes with maximum power (=cycle fuel). This should resolve the problem.